



M.M.E. TROLLEYS

T SERIES

PLAIN, GEARED & MOTORIZED

(6 TONNE)



LOW HEADROOM

COMPACT

VERSATILE

LIFTING YOUR WORLD

MME T series trolleys are designed specifically for mining, industrial and general engineering applications. The trolleys are available in plain, geared and motorized versions and can be supplied with rigid or hook on adaptors. They have a minimum factor of safety of 5 at the maximum rated load and are therefore suitable for use with both manual and powered hoists. The trolleys comply with the requirements of SANS 1824, EN13157 and EN14492-2. The manufacturing facility producing the trolleys is ISO9001, ISO14001 & OHSAS18001 certified.



Management System
ISO 9001:2008

www.tuv.com
ID 9105085673

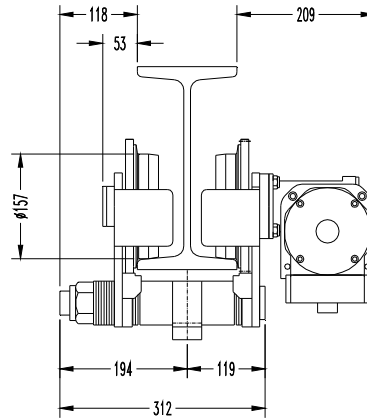
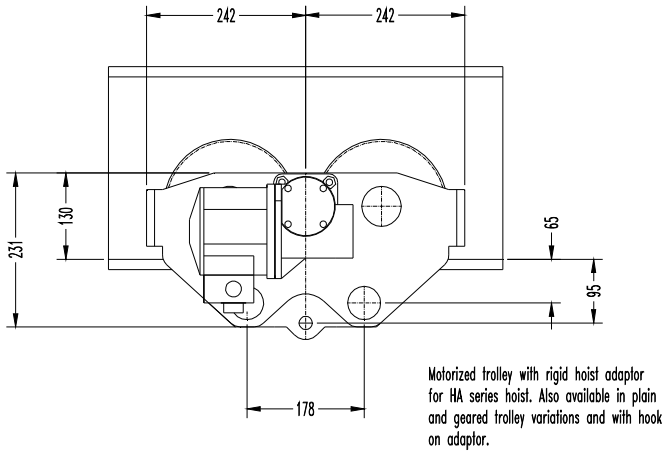

TECHNICAL SPECIFICATIONS

Model	Capacity (kg)	Flange Adjustment (mm)	Min. Curve Radius (mm)	Weight (kg)	Max. Traverse Speed (m/min) @ 6 bar
TA6000	6000	128-184	1600	80.0	27.0*
TG6000	6000	128-184	1600	72.0	-
TP6000	6000	128-184	1600	69.0	-

* Variable traverse speed is standard on the TA series trolley.

FEATURES AND CHARACTERISTICS

- Safety** : Standard throughout the range are anti fall, anti derailment and anti tilt features.
- Precise Control** : Infinitely variable control offers precise speed control from creep to full speed. The maximum allowable traverse speed can also be set on the trolley control valve.
- Emergency Stop** : All trolleys can be supplied with an emergency stop device as an option. This shuts off the main air supply to the trolley when activated. Resetting the device will not automatically restart the traverse operation.
- Low Headroom** : Compact design reduces headroom. Rigid adaptor further reduces headroom when using the HAI series hoists.
- Versatility** : Trolley fits a wide variety of beam widths. They can accommodate both parallel and tapered flange beams. Hook on adaptor allows any hoist up to trolley capacity to be attached.
- Vane Motor** : Assisted vane lifting ensures maximum starting torque when starting under load. The motor is not affected by wet or damp operating conditions. Built in silencer limits noise level to 76dB(A).
- Automatic Stopping** : Motorized traverse drive stops automatically due to the worm drive when the air supply is shut off. Additional traverse brake is optional.
- Small Turn Radius** : Trolleys can negotiate small turn radii in the support beam.
- Ease of Maintenance** : The modular design of the hoist allows easy access to internal components such as the motor, gearbox, and load limiter. Common parts are used throughout the range.

How to Order: Example: TA6000HPE2

Series	Type	Max Load (kg)	Attachment	Control	Pendent Type	Control Length (m)
T	A	6000	H	P	E	2
	A = Motorized G = Geared P = Plain		H = Hook On R = Rigid	P = Pendent T = Toggle	E = 3 Hose F = 5 Hose	

M.M.E. MANUFACTURING CO. (PTY) LTD

P.O. BOX 355 CARLETONVILLE 2500, SOUTH AFRICA

TEL: +27 (18) 788-6674/5/6

Email: info@mmelifting.com

FAX: +27 (18) 786-1479

Website: www.mmelifting.com