



M.M.E. AIR WINCHES CAW SERIES (1000 & 2000kg)

CAPSTAN AIR WINCHES



RELIABLE FAST EFFICIENT QUIET EASY MOUNTING

MOVING YOUR WORLD

MME CAW series capstan air winches are designed specifically for mining, industrial, marine and general engineering applications. The compact design of the winches allows them to be installed quickly where required. The winches have a factor of safety in excess of 5 at the rated load. They comply with the requirements of ASME B30.7. The manufacturing facility producing the winches is ISO9001, ISO14001 & OHSAS18001 certified.



Management System
ISO 9001:2008

www.tuv.com
ID 9105085673

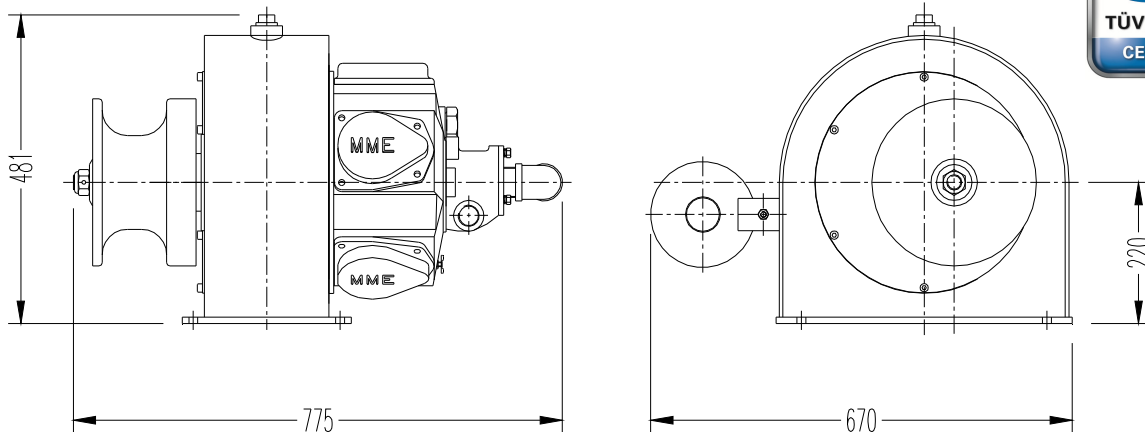

TECHNICAL SPECIFICATIONS @ 6 bar

Model	CAW1000	CAW2000
Rated Line Pull (kg)	1000	2000
Rope Speed at Rated Load (m/min)	35.0	18.7
Air Consumption (m ³ /min)	7.0	7.0
Air Connection	G1	G1
Supply Hose (Inside Ø) (mm)	32	32
Sound Level (dB(A))	83	83
Recommended Rope Size (mm)	22	28
Weight without Wire Rope (kg)	65	65

FEATURES AND CHARACTERISTICS

- Precise Control** : Infinitely variable ball valve control offers precise speed control. Ball valve varies the flow thereby giving the operator full control.
- Emergency Stop** : Optional foot mounted dead man's control. This shuts off the main air supply to the winch when released.
- Polypropylene Rope** : The use of large diameter polypropylene rope ensures a positive grip between the rope and capstan drum. Releasing the slack end immediately stops the pulling effort.
- Exhaust Silencer** : The exhaust air silencer is supplied with the winch and limits the noise level to 83dB(A). The non-clog design prevents reduced winch performance resulting from moisture, oil or dirt in the exhaust air.
- Piston Motor** : The 6kW piston motor ensures maximum torque when starting under load. The motor can be overloaded without damage occurring and is not affected by wet or damp operational conditions. Bearing mounted rotary valve ensures trouble free operation even under extreme duty cycles.
- Sealed Gearbox** : The sealed gearbox ensures that the most stringent duty cycles can be met. The gears are heat treated and mounted on high strength, low friction bearings.
- Ease of Maintenance** : The modular design of the winch allows easy access to internal components such as the motor, gearbox, and drum assembly. Common parts are used throughout the range.

M.M.E. MANUFACTURING CO. (PTY) LTD

P.O. BOX 355 CARLETONVILLE 2500, SOUTH AFRICA

TEL: +27 (18) 788-6674/5/6

Email: info@mmelifting.com

FAX: +27 (18) 786-1479

Website: www.mmelifting.com